

OSOBNÉ VÝŤAHY TRAKČNÉ - s automatickými dverami

Pôdorys šachty
Typ - ATZ

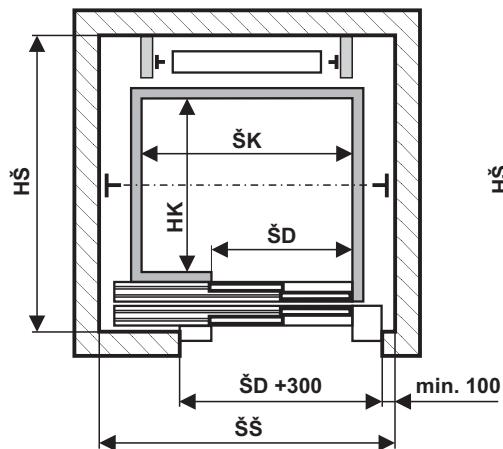

Pôdorys šachty
Typ - ACZ

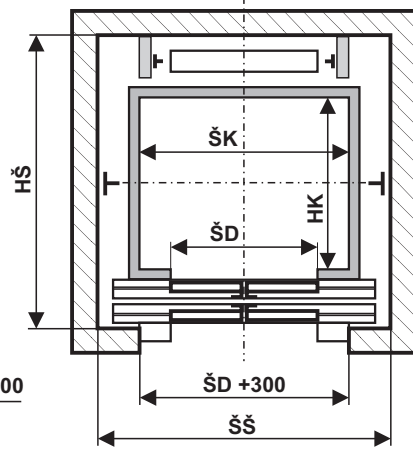

Pôdorys šachty
Typ - ATB, ATP

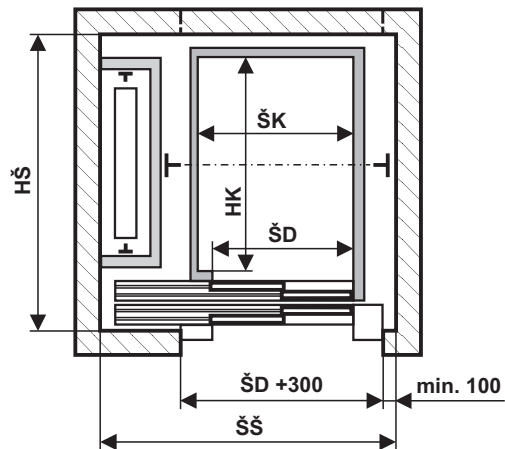

Rez šachty

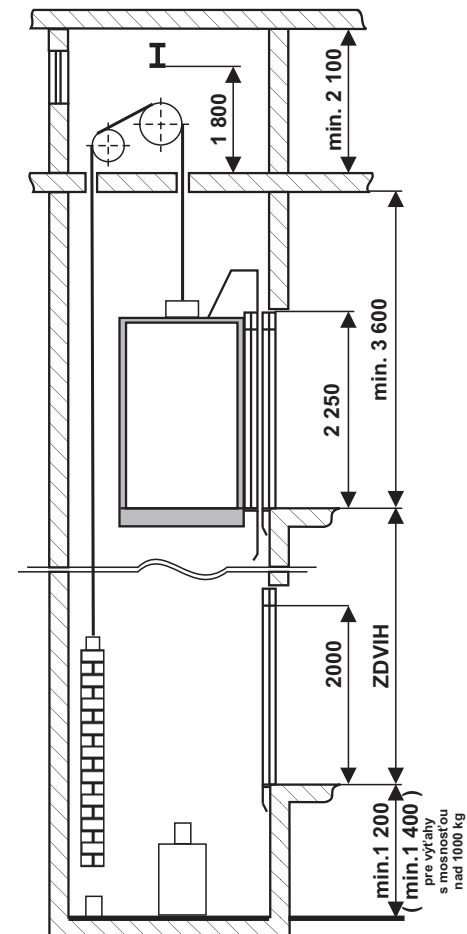

Pôdorys strojovne
Typ - ATZ, ACZ

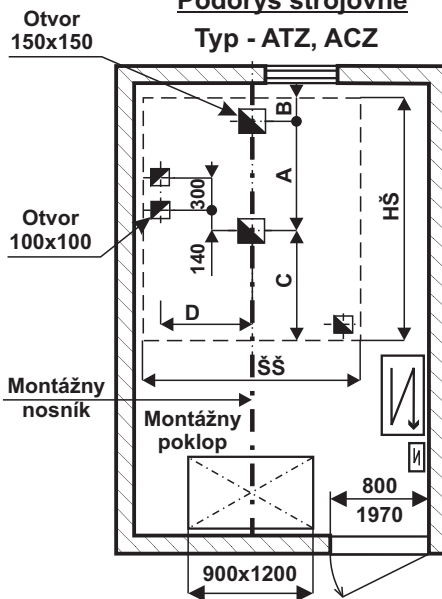

Pôdorys strojovne
Typ - ATB, ATP

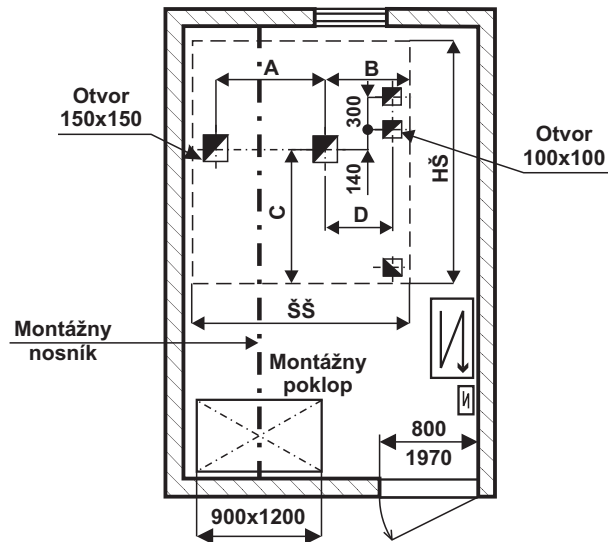

OSOBNÉ VÝŤAHY TRAKČNÉ - s automatickými dverami strojovňa nad šachtou

Typ výťahu : **TOV** – nosnosť – typ

NOSNOSŤ	OSOBY	RÝCHLOSŤ	PRÍKON	TYP	KABÍNA			ŠACHTA		STROJOVNĀ				POZN.
					ŠK	HK	ŠD	ŠŠ	HŠ	A	B	C	D	
250	3	0,63	4	ATZ	800	950	700	1300	1500	700	170	730	460	
				ACZ	800	950	700	1600	1600	670	160	670	460	
				ATB	800	950	700	1500	1300	700	650	730	460	
				ATP	800	950	700	1500	1450	700	650	730	460	
320	4	0,63	4	ATZ	900	1050	700	1500	1600	750	170	780	510	
				ACZ	900	1050	700	1600	1700	720	160	720	510	
				ATB	900	1050	700	1600	1400	750	700	780	510	
				ATP	900	1050	700	1600	1550	750	700	780	510	
450	6	0,63	5	ATZ	1000	1300	800	1700	1850	870	180	900	560	
				ACZ	1000	1300	800	1800	1950	850	160	840	560	
				ATB	1000	1300	800	1700	1650	800	750	900	560	
				ATP	1000	1300	800	1700	1800	800	750	900	560	
630	8	0,63	5	ATZ	1100	1400	800	1700	2000	950	200	950	610	INVALIDNÝ
				ACZ	1100	1400	800	1800	2100	930	180	890	610	INVALIDNÝ
				ATB	1100	1400	800	1800	1800	850	800	950	610	INVALIDNÝ
				ATP	1100	1400	800	1800	1900	850	800	950	610	INVALIDNÝ
800	11	0,63	7	ATZ	1200	1600	900	1900	2200	1100	200	1050	660	
				ACZ	1200	1600	900	2000	2250	1080	180	990	660	
				ATB	1200	1600	900	2000	2000	950	850	1050	660	
				ATP	1200	1600	900	2000	2100	950	850	1050	660	
1000	13	0,63	9	ATZ	1300	1800	1000	2100	2500	1200	200	1150	710	
				ATB	1300	1800	1000	2150	2200	1000	900	1150	710	
				ATP	1300	1800	1000	2150	2300	1000	900	1150	710	
1600	21	0,63	11	ATZ	1400	2400	1300	2200	3150	1500	250	1450	760	LŔŽKOVÝ
				ATB	1400	2400	1300	2250	2800	1050	950	1450	760	LŔŽKOVÝ
				ATP	1400	2400	1300	2250	2900	1050	950	1450	760	LŔŽKOVÝ

Legenda : **ATZ** - automatické teleskopické dvere, protiváha za kabínou
ACZ - automatické centrálné dvere, protiváha za kabínou
ATB - automatické teleskopické dvere, protiváha vedľa kabíny
ATP - automatické teleskopické dvere, prechodná kabína

ŠK, HK - rozmery kabíny
ŠD - šírka dverí
ŠŠ, HŠ - rozmery šachty
A,B,C,D - otvory medzi strojovňou a šachtou